



R585M

▶ 1.

▶ 1.

▶ 2.

▶ 2.

▶ 3.

▶ 4.



R585M

R585M

GIACOMINI



R585M



R585T

R585M

(R585T.) 3/4" 1". R585M, R585T

; R179- PEX PB GIACOMINI ; R179AM- 16. : R178 -

R253,

- . : 90°C
- . : 1 MPa
-
-
-
-
-
-
- EP
- DN20 (3/4") DN25 (1")
- 35 mm
- 16

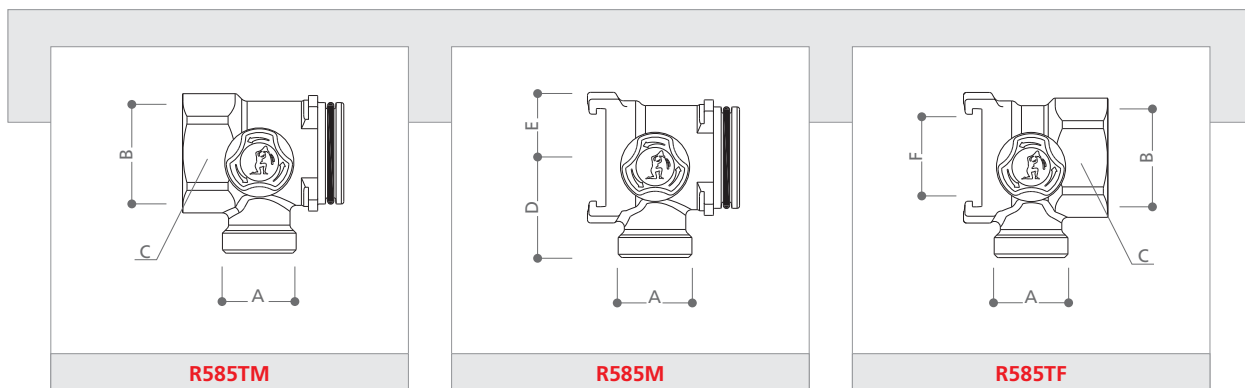

	A	B	C	D	E	F
R585MX105	16	-	-	32	21	DN25
R585TX104	16	3/4"	○ 31	32	21	DN25
R585TX105	16	1"	○ 39	32	21	DN25



R585M

R585M

R585T.

90

(R585T) (

(R585M),

1 . R585T 4 .

6
R585M.

(DN25),
(3/4" 1").

(R585T,)

R584E/F

16.

R523,



, R585M

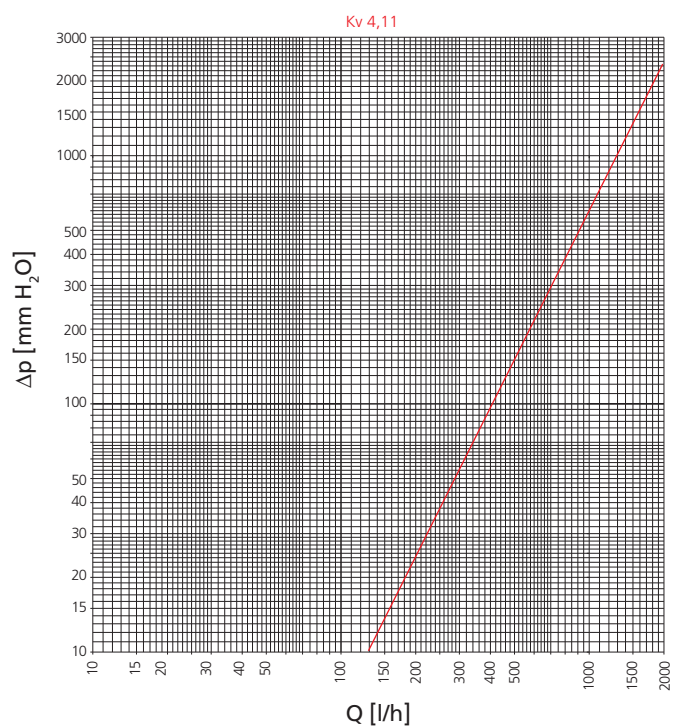

	Kv
1/2	0,23
3/4	0,36
1	0,48
1 1/2	0,68
2	0,87
T.A.	1,45



ISO 9001: 2000



R585M



GIACOMINI SPA
Via per Alzo,39
28017 San Maurizio d'Opaglio (NO) ITALY
tel. 0322 923111 - fax 0322 96256
e-mail: info@giacomini.com
internet: www.giacomini.com

“ ”
“ ” 253
./ : 02 / 85 69 174
. : +359 878 20 55 33
sales@terratherm-bg.com
www.terratherm-bg.com