



R53MM



R53MM -

R53MM DN32

R53MM DN32

R53MM

R53MT DN32,
1" 1 1/4".

R53MT DN32

(30 l/h 300 l/h),

18,

R53MM DN32

- 90
- 1 Mpa (10 bar)

- 1" 1 1/4"

- 50

18

- DN32
0.5 - 5 l/min





R53MM -

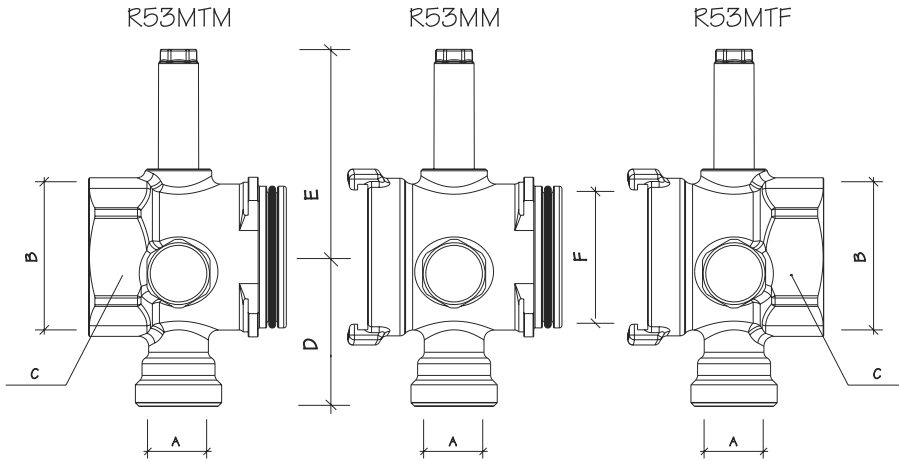

	A	B	C	D	E	F
R53MMY006	18	-	-	46	62	DN32
R53MTY006	18	1"	∅ 39	46	62	DN32
R53MTY007	18	1"1/4	∅ 48	46	62	DN32

R53MM



90

R53MT,
R53MM,

1 . R53MT 3 5
1 . R53MT, 2 . R53MM;





R53MM -

R53MT DN32, 1" 1"1/4
R588D,
GIACOMINI 18,
R501 R502, R500,

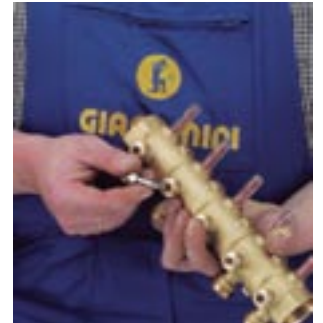

R53MM DN32,

2.

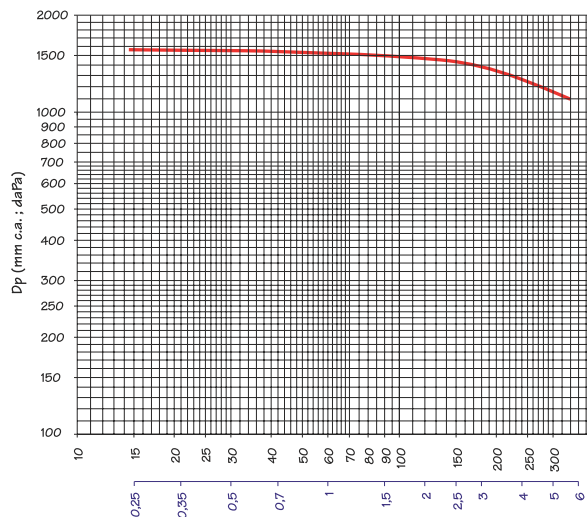

l/min	Kv
0,5	0,08
1	0,14
2	0,30
3	0,46
4	0,66
5	0,89



GIACOMINI SPA
Via per Alzo,39
28017 San Maurizio d'Opaglio (NO) ITALY
tel. 0322 923111 - fax 0322 96256
e-mail: info@giacomini.com
internet: www.giacomini.com

1618

“ ”
“ ” 253
./ : 02 / 85 69 174
.: +359 878 20 55 33
sales@terratherm-bg.com
www.terratherm-bg.com